

CURRENT OWNER		TOPO.	UTILITIES	STRT./ROAD	LOCATION	CURRENT ASSESSMENT			
VERTERAMO MICHAEL P VERTERAMO ROBIN P 167 PLEASANT ST			1 TYPCL			Description	Code	Appraised Value	Assessed Value
EAST LONGMEADOW, MA 01028 Additional Owners:						RESIDENTL. RES LAND	101 101	105,800 75,600	105,800 75,600
SUPPLEMENTAL DATA									
Other ID: SP Permit Chapter Land OC Dates In+Ex FY Mailed GIS ID: F_383932_2851617				Received Prior ID Owner Occ Final Area Current Ac. ASSOC PID#					
						Total		181,400	181,400

VISION

1006
AST LONGMEADOW, MA

RECORD OF OWNERSHIP		BK-VOL/PAGE	SALE DATE	q/u	v/i	SALE PRICE	V.C.	PREVIOUS ASSESSMENTS (HISTORY)								
VERTERAMO MICHAEL P HEALD THEO RUTH,ESTATE OF		19606/ 101 02723/ 0490	12/21/2012 01/11/1960	U U	I I	130,000 0	1H	Yr.	Code	Assessed Value	Yr.	Code	Assessed Value	Yr.	Code	Assessed Value
								2015	101	105,800	2014	B	103,500	2013	B	108,500
								2015	101	75,600	2014	L	78,700	2013	L	78,700
								Total:		181,400	Total:		182,200	Total:		187,200

EXEMPTIONS				OTHER ASSESSMENTS			
Year	Type	Description	Amount	Code	Description	Number	Amount
Total:							

This signature acknowledges a visit by a Data Collector or Assessor

ASSESSING NEIGHBORHOOD				
NBHD/ SUB	NBHD Name	Street Index Name	Tracing	Batch
0001/A			101	MA

APPRAISED VALUE SUMMARY

Appraised Bldg. Value (Card)	105,800
Appraised XF (B) Value (Bldg)	0
Appraised OB (L) Value (Bldg)	0
Appraised Land Value (Bldg)	75,600
Special Land Value	0
Total Appraised Parcel Value	181,400
Valuation Method:	C
Adjustment:	0
Net Total Appraised Parcel Value	181,400

NOTES

SEE OFFICE NOTES
 FY15 PLAN 1111 BK PG 367-73 NEW LOT B
 2000 SF TO 37-46-3

BUILDING PERMIT RECORD									VISIT/ CHANGE HISTORY					
Permit ID	Issue Date	Type	Description	Amount	Insp. Date	% Comp.	Date Comp.	Comments	Date	Type	IS	ID	Cd.	Purpose/Result
									11/15/2013			317	2	MEASURED
									11/21/2002			274	3	MEAS+INSPCTD
									02/10/1992			105	3	MEAS+INSPCTD
									10/09/1980			500	3	MEAS+INSPCTD

LAND LINE VALUATION SECTION

B #	Use Code	Use Description	Zone	D	Front	Depth	Units	Unit Price	I. Factor	S.A.	Acre Disc	C. Factor	ST. Idx	Adj.	Notes- Adj	Special Pricing		S Adj Fact	Adj. Unit Price	Land Value	
																Spec Use	Spec Calc				
1	101	ONE FAM	RA				28,000	SF	3.00	1.0000	5	1.0000	1.00	MA	1.00		TRF2	90	.90	2.70	75,600

CONSTRUCTION DETAIL				CONSTRUCTION DETAIL (CONTINUED)			
Element	Cd.	Ch.	Description	Element	Cd.	Ch.	Description
Style	05		CAPE	#Heat Sys	1		
Model	01		RESIDENTIAL	Central Vac	0		NO
Grade	C		AVERAGE	FBM Sqft	717		
Stories	1.50		1 1/2 Stories	Int vs Ext	S		
Foundation	2		CONC BLOCK	MIXED USE			
Exterior Wall 1	3		ALUMINUM	<i>Code</i>	<i>Description</i>		<i>Percentage</i>
Exterior Wall 2				101	ONE FAM		100
Roof Structure	1		GABLE	COST/MARKET VALUATION			
Roof Cover	1		ASPHALT SH	Adj. Base Rate:	89.41		
Interior Wall 1	2		PLASTER	Replace Cost	173,446		
Interior Wall 2	8		PLYWD PANL	AYB	1949		
Interior Floor 1	3		HARDWOOD	EYB	1975		
Interior Floor 2	4		CARPET	Dep Code	AV		
Heat Fuel	2		GAS	Remodel Rating			
Heat Type	1		FORCED H/A	Year Remodeled			
AC Type	03		FULL	Dep %	39		
Bedrooms	3			Functional Obslnc			
Full Baths	1			External Obslnc			
Half Baths	0			Cost Trend Factor	1		
Extra Fixtures	1			Condition			
Total Rooms	6			% Complete			
Bath Style	A		AVERAGE	Overall % Cond	61		
Kitchen Style	A		AVERAGE	Apprais Val	105,800		
Kitchens	1			Dep % Ovr	0		
Extra Kitchens	0			Dep Ovr Comment			
Frame	1		WOOD	Misc Imp Ovr	0		
Basement Floor	5			Misc Imp Ovr Comment			
Bsmt Garage				Cost to Cure Ovr	0		
Units	1			Cost to Cure Ovr Comment			
WS Flues							
FBM Quality	1						
Fireplaces	1						

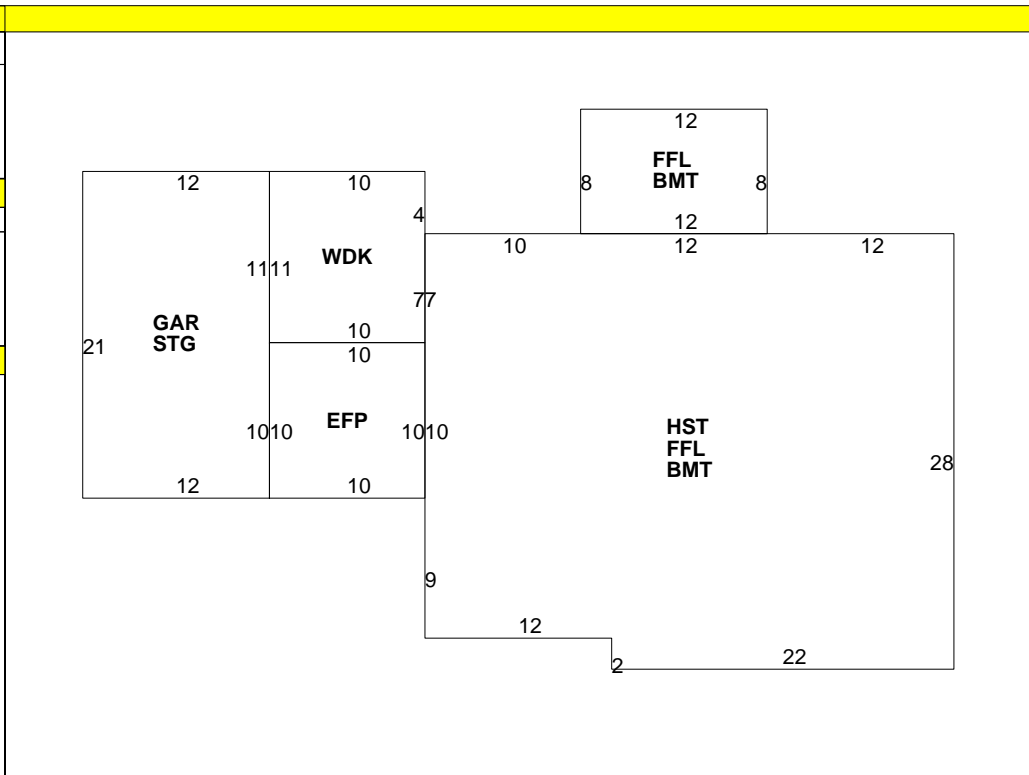

OB-OUTBUILDING & YARD ITEMS(L) / XF-BUILDING EXTRA FEATURES(B)

Code	Description	Sub	Sub Descript	L/B	Units	Unit Price	Yr	Gde	Dp Rt	Cnd	%Cnd	Apr Value

BUILDING SUB-AREA SUMMARY SECTION

Code	Description	Living Area	Gross Area	Eff. Area	Unit Cost	Undeprec. Value
BMT	BASEMENT	0	1,024		17.90	18,328
EFP	ENCL PORCH	0	100		26.82	2,682
FFL	1ST FLOOR	1,024	1,024		89.41	91,551
GAR	GARAGE	0	252		35.83	9,030
HST	HALF STORY	464	928		44.70	41,484
STG	STORAGE	0	252		35.83	9,030
WDK	WOOD DECK	0	110		12.19	1,341
Ttl. Gross Liv/Lease Area:		1,488	3,690	1,940		173,446

