

CURRENT OWNER		TOPO.	UTILITIES	STRT./ROAD	LOCATION	CURRENT ASSESSMENT			
CARABETTA ROCCO M JR CARABETTA LINDA P 16 REDSTONE DR			1 TYPCL			Description	Code	Appraised Value	Assessed Value
EAST LONGMEADOW, MA 01028 Additional Owners:		SUPPLEMENTAL DATA				RESIDENTL.	101	187,600	187,600
						RES LAND	101	88,500	88,500
						Total		276,100	276,100

1006
AST LONGMEADOW, MA
VISION

RECORD OF OWNERSHIP		BK-VOL/PAGE	SALE DATE	q/u	v/i	SALE PRICE	V.C.	PREVIOUS ASSESSMENTS (HISTORY)								
CARABETTA ROCCO M JR		04450/ 0227	07/13/1977	U	I	0		Yr.	Code	Assessed Value	Yr.	Code	Assessed Value	Yr.	Code	Assessed Value
								2016	101	185,600	2015	101	185,600	2014	B	177,700
								2016	101	85,800	2015	101	85,800	2014	L	88,700
								Total:		271,400	Total:		271,400	Total:		266,400

EXEMPTIONS				OTHER ASSESSMENTS			
Year	Type	Description	Amount	Code	Description	Number	Amount
Total:							

This signature acknowledges a visit by a Data Collector or Assessor

ASSESSING NEIGHBORHOOD				
NBHD/ SUB	NBHD Name	Street Index Name	Tracing	Batch
0001/A			101	MA

APPRAISED VALUE SUMMARY

Appraised Bldg. Value (Card)	187,600
Appraised XF (B) Value (Bldg)	0
Appraised OB (L) Value (Bldg)	0
Appraised Land Value (Bldg)	88,500
Special Land Value	0
Total Appraised Parcel Value	276,100
Valuation Method:	C
Adjustment:	0
Net Total Appraised Parcel Value	276,100

NOTES

1/2 BATH IN BMT WOOD STOVE HAS 65 GAL WATER EXCHANGE TO HEAT HOUSE - SUB DIV 945-FY13 SUB DIV 1089 BK PLANS 362-7-NEW LOT 6. FY13 ABT GRANTED

BUILDING PERMIT RECORD										VISIT/ CHANGE HISTORY					
Permit ID	Issue Date	Type	Description	Amount	Insp. Date	% Comp.	Date Comp.	Comments	Date	Type	IS	ID	Cd.	Purpose/Result	
270	09/08/2004	37	3 SEASON RM	15,000		0		14' X 20' TO REPLACE	12/30/2011			317	3	MEAS+INSPCTD	
44	03/17/2000	1	PORCH	2,500		0		FRONT PRCH	12/30/2005			311	15	PERMIT VISIT	
31	01/01/1986	MN	Manual Note	0		0		ADDITION	12/28/2004			311	15	PERMIT VISIT	
									04/07/2004			317	14	INSPECTED	
									03/26/2004			250	22	MAILER SENT	

LAND LINE VALUATION SECTION																						
B #	Use Code	Use Description	Zone	D	Front	Depth	Units	Unit Price	I. Factor	S.A.	Acre Disc	C. Factor	ST. Idx	Adj.	Notes- Adj	Special Pricing				S Adj Fact	Adj. Unit Price	Land Value
																Spec Use	Spec Calc					
1	101	ONE FAM	RA				33,918	SF	2.53	1.0300	5	1.0000	1.00	MA	1.00					1.00	2.61	88,500

CONSTRUCTION DETAIL				CONSTRUCTION DETAIL (CONTINUED)			
Element	Cd.	Ch.	Description	Element	Cd.	Ch.	Description
Style	19		RANCH	#Heat Sys	2		
Model	01		RESIDENTIAL	Central Vac	1		
Grade	C+		AVG. (+)	FBM Sqft			
Stories	1.00		1 Story	Int vs Ext	S		
Foundation	1						
Exterior Wall 1	4		VINYL				
Exterior Wall 2	8		BRICK VENR				
Roof Structure	1		GABLE				
Roof Cover	1		ASPHALT SH				
Interior Wall 1	1		DRYWALL				
Interior Wall 2							
Interior Floor 1	3		HARDWOOD				
Interior Floor 2	4		CARPET				
Heat Fuel	2		GAS				
Heat Type	3		FORCED H/W				
AC Type	03		Full				
Bedrooms	2						
Full Baths	2						
Half Baths	1						
Extra Fixtures	2						
Total Rooms	5						
Bath Style	G		GOOD				
Kitchen Style	A		AVERAGE				
Kitchens	1						
Extra Kitchens	0						
Frame	1		WOOD				
Basement Floor	12						
Bsmt Garage							
Units	1						
WS Flues	1						
FBM Quality							
Fireplaces	2						

MIXED USE

Code	Description	Percentage
101	ONE FAM	100

COST/MARKET VALUATION

Adj. Base Rate:	91.77
Replace Cost	231,548
AYB	1978
EYB	1995
Dep Code	GD
Remodel Rating	
Year Remodeled	
Dep %	19
Functional Obslnc	
External Obslnc	
Cost Trend Factor	1
Condition	
% Complete	
Overall % Cond	81
Apprais Val	187,600
Dep % Ovr	0
Dep Ovr Comment	
Misc Imp Ovr	0
Misc Imp Ovr Comment	
Cost to Cure Ovr	0
Cost to Cure Ovr Comment	

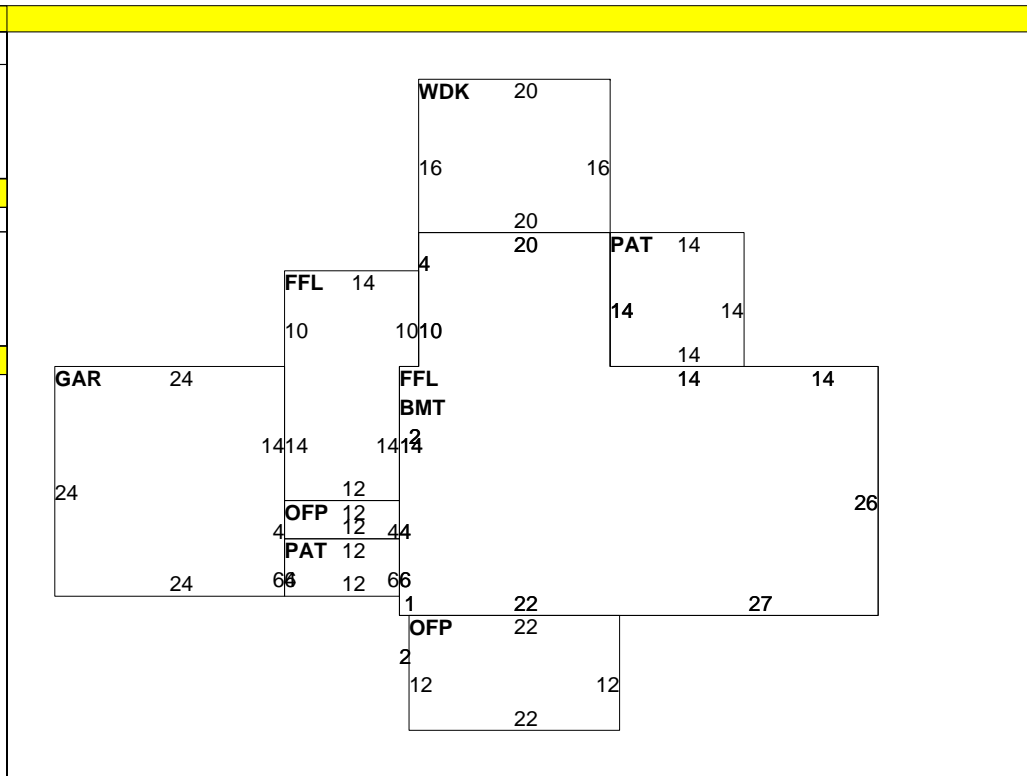

OB-OUTBUILDING & YARD ITEMS(L) / XF-BUILDING EXTRA FEATURES(B)												
Code	Description	Sub	Sub Descript	L/B	Units	Unit Price	Yr	Gde	Dp Rt	Cnd	%Cnd	Apr Value

BUILDING SUB-AREA SUMMARY SECTION

Code	Description	Living Area	Gross Area	Eff. Area	Unit Cost	Undeprec. Value
BMT	BASEMENT	0	1,580		18.35	29,001
FFL	1ST FLOOR	1,888	1,888		91.77	173,271
GAR	GARAGE	0	576		36.65	21,108
OFF	OPEN PORCH	0	312		9.12	2,845
PAT	PATIO	0	268		4.45	1,193
WDK	WOOD DECK	0	320		12.91	4,130

Ttl. Gross Liv/Lease Area: 1,888 4,944 2,523 231,548

