

CURRENT OWNER		TOPO.	UTILITIES	STRT./ROAD	LOCATION	CURRENT ASSESSMENT			
BOTTA GENESIO BOTTA MARIA 75 BRYNMAWR DR		1	TYPCL			Description	Code	Appraised Value	Assessed Value
EAST LONGMEADOW, MA 01028 Additional Owners:		SUPPLEMENTAL DATA				RESIDENTL.	101	138,700	138,700
						RES LAND	101	104,300	104,300
						RESIDENTL.	101	12,900	12,900
						Total		255,900	255,900

1006
AST LONGMEADOW, M
VISION

RECORD OF OWNERSHIP		BK-VOL/PAGE	SALE DATE	q/u	v/i	SALE PRICE	V.C.	PREVIOUS ASSESSMENTS (HISTORY)								
BOTTA GENESIO		09463/ 0548	04/26/1996	U	1	150,000		Yr.	Code	Assessed Value	Yr.	Code	Assessed Value	Yr.	Code	Assessed Value
SCHUHLEN KEITH + KELLY O'		07805/ 0224	09/13/1991	U	1	150,000		2017	101	138,600	2016	101	137,300	2015	101	137,300
MORRISSEY JOHN + HOLT		6430/ 024	05/27/1987	U	1	143,000		2017	101	102,000	2016	101	98,800	2015	101	98,800
		05500/ 0072	09/16/1983	U	1	78,500		2017	101	12,900	2016	101	12,900	2015	101	12,900
								Total:		253,500	Total:		249,000	Total:		249,000

EXEMPTIONS				OTHER ASSESSMENTS			
Year	Type	Description	Amount	Code	Description	Number	Amount
Total:							

This signature acknowledges a visit by a Data Collector or Assessor

ASSESSING NEIGHBORHOOD				
NBHD/ SUB	NBHD Name	Street Index Name	Tracing	Batch
0001/A			101	MG

APPRAISED VALUE SUMMARY	
Appraised Bldg. Value (Card)	138,700
Appraised XF (B) Value (Bldg)	0
Appraised OB (L) Value (Bldg)	12,900
Appraised Land Value (Bldg)	104,300
Special Land Value	0
Total Appraised Parcel Value	255,900
Valuation Method:	C
Adjustment:	0
Net Total Appraised Parcel Value	255,900

NOTES	
KITCHEN IN BASEMENT	

BUILDING PERMIT RECORD							
Permit ID	Issue Date	Type	Description	Amount	Insp. Date	% Comp.	Date Comp.
119	05/01/1987	MN	Manual Note	4,200		0	

VISIT/ CHANGE HISTORY					
Date	Type	IS	ID	Cd.	Purpose/Result
09/01/2005			311	3	MEAS+INSPCTD
06/08/2005			250	22	MAILER SENT
06/07/2005			274	2	MEASURED
01/17/2000			247	14	INSPECTED
11/22/1999			247	2	MEASURED

LAND LINE VALUATION SECTION																					
B #	Use Code	Use Description	Zone	D	Front	Depth	Units	Unit Price	I. Factor	S.A.	Acre Disc	C. Factor	ST. Idx	Adj.	Notes- Adj	Special Pricing			S Adj Fact	Adj. Unit Price	Land Value
																Spec Use	Spec Calc				
1	101	ONE FAM	RA				25,000	SF	3.50	1.1900	7	1.0000	1.00	MG	1.00				1.00	4.17	104,300

CONSTRUCTION DETAIL				CONSTRUCTION DETAIL (CONTINUED)			
Element	Cd.	Ch.	Description	Element	Cd.	Ch.	Description
Style	18		SPLIT ENT	#Heat Sys	1		
Model	01		RESIDENTIAL	Central Vac	0		NO
Grade	C		AVERAGE	FBM Sqft	564		
Stories	1.00		1 STORY	Int vs Ext	S		SAME
Foundation	1		CONCRETE	MIXED USE			
Exterior Wall 1	4		VINYL	<i>Code</i>	<i>Description</i>		<i>Percentage</i>
Exterior Wall 2				101	ONE FAM		100
Roof Structure	1		GABLE	COST/MARKET VALUATION			
Roof Cover	1		ASPHALT SH	Adj. Base Rate:			117.89
Interior Wall 1	1		DRYWALL	Replace Cost			190,045
Interior Wall 2				AYB			1971
Interior Floor 1	3		HARDWOOD	EYB			1990
Interior Floor 2				Dep Code			GD
Heat Fuel	2		GAS	Remodel Rating			
Heat Type	3		FORCED H/W	Year Remodeled			
AC Type	01		NONE	Dep %			27
Bedrooms	3			Functional Obslnc			
Full Baths	1			External Obslnc			
Half Baths	2			Cost Trend Factor			1
Extra Fixtures	0			Condition			
Total Rooms	6			% Complete			
Bath Style	A		AVERAGE	Overall % Cond			73
Kitchen Style	A		AVERAGE	Apprais Val			138,700
Kitchens	2			Dep % Ovr			0
Extra Kitchens	0			Dep Ovr Comment			
Frame	1		WOOD	Misc Imp Ovr			0
Basement Floor	12		CONCRETE	Misc Imp Ovr Comment			
Bsmt Garage	2			Cost to Cure Ovr			0
Units	1			Cost to Cure Ovr Comment			
WS Flues							
FBM Quality	3						
Fireplaces	1						

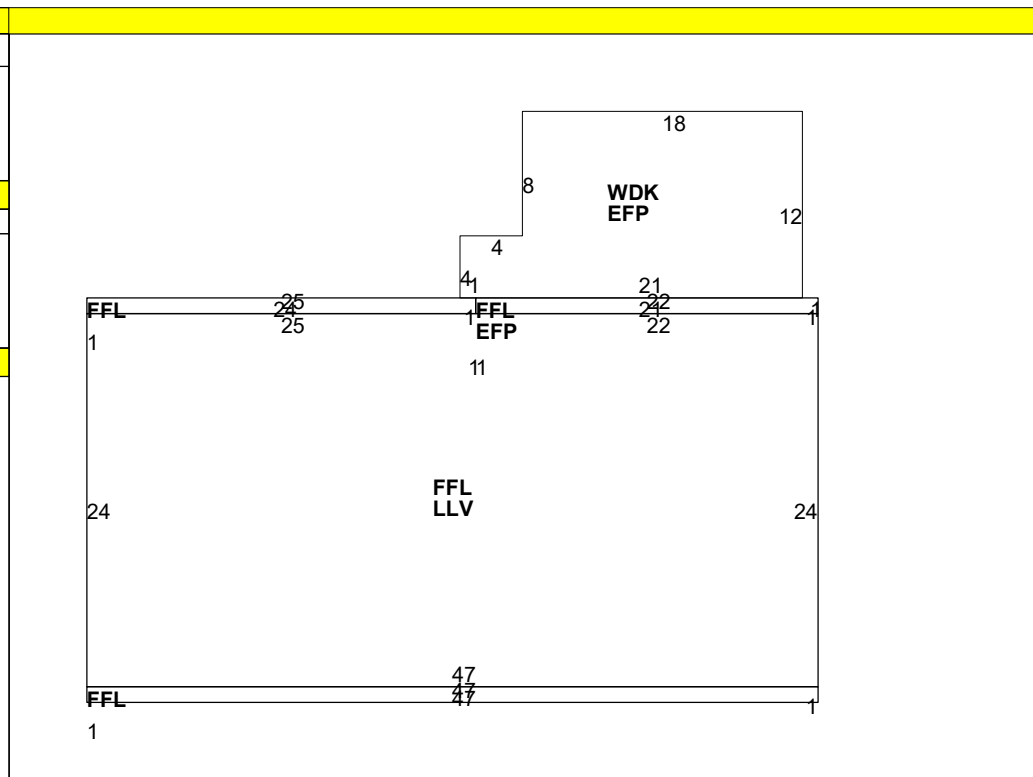

OB-OUTBUILDING & YARD ITEMS(L) / XF-BUILDING EXTRA FEATURES(B)												
Code	Description	Sub	Sub Descript	L/B	Units	Unit Price	Yr	Gde	Dp Rt	Cnd	%Cnd	Apr Value
02	SHED/FR			L	96	7.48	1974	A		AV	60	400
11	POOL I-V	OB	Outbuilding	L	512	29.00	1983	A		AV	60	8,900
22	WOOD DK			L	640	9.20	1987	A		AV	60	3,500
02	SHED/FR			L	32	7.48	1990	A		AV	60	100

BUILDING SUB-AREA SUMMARY SECTION						
Code	Description	Living Area	Gross Area	Eff. Area	Unit Cost	Undeprec. Value
EFP	ENCL PORCH	0	254		35.28	8,960
FFL	1ST FLOOR	1,222	1,222		117.89	144,066
LLV	LOWR LEVEL	0	1,128		29.47	33,246
WDK	WOOD DECK	0	232		16.26	3,773
Ttl. Gross Liv/Lease Area:		1,222	2,836	1,612		190,045

