

CURRENT OWNER		TOPO TYPE	UTILITY	STREET	LOCATION	CURRENT ASSESSMENT				
SCULLY MAUREEN H 130 AVERY ST EAST LONGMEADOW MA 01028						Description	Code	Appraised	Assessed	1006 EAST LONGMEADOW
		TOPO WET	EASEMENT	TRAFFIC	CORNER	RESIDNTL.	101	185300	185,300	
						RES LAND	101	98400	98,400	
		DRAINAGE		VIEW	COMMUNITY	RESIDNTL.	101	800	800	
SUPPLEMENTAL DATA						Total		284,500	284,500	
GIS ID F_376004_2851474		Alt Prcl ID SP Permit Chapter Land OC Dates In+Ex FY Mailed		Received NIA Field 8 Field 9 Field 10 Assoc Pid#						

RECORD OF OWNERSHIP		BK-VOL/PAGE	SALE DATE	Q/U	V/I	SALE PRICE	VC	PREVIOUS ASSESSMENTS (HISTORY)										
SCULLY MAUREEN H		13601	0140	09-17-2003	U	I	1	1	Year	Code	Assessed	Year	Code	Assessed	Year	Code	Assessed	
SCULLY WAYNE P + MAUREEN H,		04430	0141	06-02-1977	U	I	0		2021	101	177,900	2020	101	169,000	2019	101	164,600	
										101	91,000		101	91,000		101	88,200	
										101	800		101	800		101	800	
		Total						Total		269,700		Total		260,800		Total		253,600

EXEMPTIONS				OTHER ASSESSMENTS				This signature acknowledges a visit by a Data Collector or Assessor										
Year	Code	Description	Amount	Code	Description	YEAR	Amount	Comm Int										
Total			0.00															

ASSESSING NEIGHBORHOOD						APPRAISED VALUE SUMMARY											
Nbhd	Nbhd Name		B	Tracing		Batch											
0001				101		NA											
NOTES																	
Appraised BLDG. Value (Card) 185,300																	
Appraised Xf (B) Value (Bldg) 0																	
Appraised Ob (B) Value (Bldg) 800																	
Appraised Land Value (Bldg) 98,400																	
Special Land Value 0																	
Total Appraised Parcel Value 284,500																	
Valuation Method C																	
Adjustment																	
Net Total Appraised Parcel Value 284,500																	

BUILDING PERMIT RECORD										VISIT / CHANGE HISTORY					
Permit Id	Issue Date	Type	Description	Amount	Insp Date	% Comp	Date Comp	Comments	Date	Type	Is	Id	Cd	Purpose/Result	
201500366	02-18-2015	91	INSULATION	4,000		0			03-21-2018			333	2	MEASURED	
89	04-01-1990	MN	Manual Note	30,000				ADDN	04-30-2004			317	14	INSPECTED	
138	05-01-1988	MN	Manual Note	1,175				SHED	04-06-2004			250	22	MAILER SENT	
									03-30-2004			319	2	MEASURED	
									01-08-1991			107	15	PERMIT VISIT	
									08-27-1990			131	2	MEASURED	
									12-03-1988			150	14	INSPECTED	

LAND LINE VALUATION SECTION																						
B	Use Co	Description	Zone	D	Fronta	Depth	Land Units	Unit Price	I. Fact	S.A.	Ac Di	C. Fact	St. Idx	Adj	Notes	Special Pricing			Size A	Adj Unit Pric	Land Value	
1	101	ONE FAM	RB				17,472 SF	5.41	1.040	6	LAND	1.00	NA	1.00		0			1.000	5.63	98,400	
Total Card Land Units							0.40	AC	Parcel Total Land Area:				0.40								Total Land Value	98,400

CONSTRUCTION DETAIL			CONSTRUCTION DETAIL (CONTINUED)		
Element	Cd	Description	Element	Cd	Description
Style	19	RANCH	Basement Floor	12	CONCRETE
Model	01	RESIDENTIAL	Bsmt Garage		
Grade	C	AVERAGE	#Heat Sys	1.00	
Stories	1.00	1 STORY	Units	1	
Foundation	1	CONCRETE	MIXED USE		
Exterior Wall 1	4	VINYL	Code	Description	Percentage
Exterior Wall 2	8	BRICK VENR	101	ONE FAM	100
Roof Structure	2	HIP			0
Roof Cover	1	ASPHALT SH			0
Interior Wall 1	1	DRYWALL	COST / MARKET VALUATION		
Interior Wall 2			Adj Base Rate		99.71
Interior Floor 1	4	CARPET	RCN		250,383
Interior Floor 2	6	CERAMIC TL	Net Other Adj		
Heat Fuel	3	ELECTRIC	Year Built		1975
Heat Type	6	ELECTRC BB	Effective Year Built		1992
AC Type	01	NONE	Depreciation Code		GD
Bedrooms	3		Remodel Rating		
Full Baths	2		Year Remodeled		
Half Baths	1		Depreciation %		26
Extra Fixtures	0		Functional Obsol		
Total Rooms	6		External Obsol		
Bath Style	A	AVERAGE	Cost Trend Factor		1
Half Bath Style	A	AVERAGE	Condition		
Kitchens	1		% Complete		
Kitchen Style	G	GOOD	Overall % Condition		74
Extra Kitchens	0		RCNLD		185,300
Extra Kitchen St			Dep % Ovr		
FBM Sqft	1222		Dep Ovr Comment		
FBM Quality	1		Misc Imp Ovr		
Fireplaces	1		Misc Imp Ovr Comment		
WS Flues			Cost to Cure Ovr		
Central Vac	0	NO	Cost to Cure Ovr Comment		
Frame	1	WOOD			

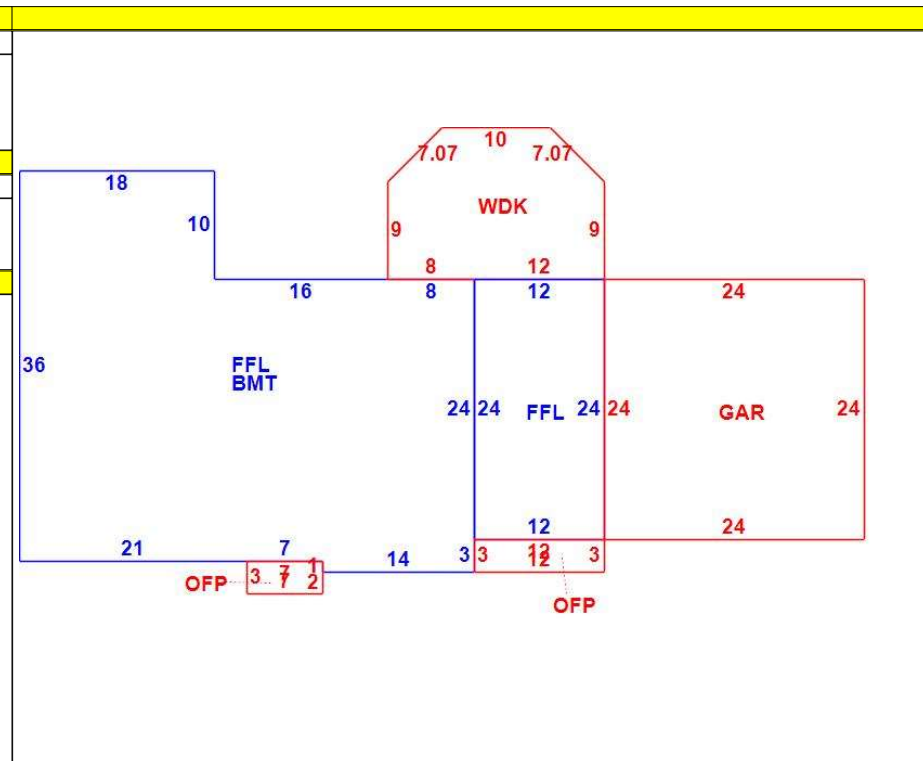

OB - OUTBUILDING & YARD ITEMS(L) / XF - BUILDING EXTRA FEATURES(B)													
Code	Description	Su	Sub Type	Lan	Units	Unit Price	Yr Blt	%	Dep.	Cond	Gra	Qual	Apprais Va
02	SHED/FR			L	120	7.48	1988	70	0.00	GD	G	1.25	800

BUILDING SUB-AREA SUMMARY SECTION							
Subarea	Description	Living	Gross	Eff Area	Unit Cost	Undeprec Value	
BMT	BASEMENT	0	1,286		23.79	30,598	
FFL	1ST FLOOR	1,574	1,574		119.06	187,400	
GAR	GARAGE	0	576		47.54	27,384	
OFF	OPEN PORCH	0	57		12.53	714	
WDK	WOOD DECK	0	255		16.81	4,286	
Ttl Gross Liv / Lease Area		1,574	3,748	2,103		250,383	

