

Property Location 51 ALLEN ST
 Vision ID 4415

Account # 4484

Map ID 58/ 48/ 0/ /

Bldg # 1

Bldg Name
 Sec # 1 of 1

Card # 1 of 1

State Use 101
 Print Date 12/12/2022 9:54:42 P

| CURRENT OWNER | | TOPO TYPE | UTILITY | STREET | LOCATION | CURRENT ASSESSMENT | | | | | | | | | | | | | | | |
|--------------------------------|------------|-------------------|-------------|-------------------|-----------------------|--------------------|------------|---|------------|-----------------|-------|---------|------------------|----------------|-------|-----------------|------|---------|--------|---------------|------------|
| HOLOTKA JOANNE | | | | | | Description | Code | Appraised | Assessed | 1006 | | | | | | | | | | | |
| 3640 CLOUDLAND DR | | TOPO WET | EASEMENT | TRAFFIC | CORNER | RESIDNTL. | 101 | 205900 | 205,900 | EAST LONGMEADOW | | | | | | | | | | | |
| ATLANTA GA 30327 | | DRAINAGE | | VIEW | COMMUNITY | RES LAND | 101 | 137900 | 137,900 | | | | | | | | | | | | |
| GIS ID F_388351_2857261 | | SUPPLEMENTAL DATA | | | Total 343,800 343,800 | | | | | | | | | | | | | | | | |
| Alt Prcl ID | | Received | | | | | | | | | | | | | | | | | | | |
| SP Permit | | NIA | | | | | | | | | | | | | | | | | | | |
| Chapter Land | | Field 8 | | | | | | | | | | | | | | | | | | | |
| OC Dates | | Field 9 | | | | | | | | | | | | | | | | | | | |
| In+Ex FY | | Field 10 | | | | | | | | | | | | | | | | | | | |
| Mailed | | Assoc Pid# | | | | | | | | | | | | | | | | | | | |
| RECORD OF OWNERSHIP | | BK-VOL/PAGE | SALE DATE | Q/U | V/I | SALE PRICE | VC | PREVIOUS ASSESSMENTS (HISTORY) | | | | | | | | | | | | | |
| HOLOTKA JOANNE | | 20912 0494 | 10-15-2015 | U | I | 100 | 1 | Year | Code | Assessed | Year | Code | Assessed | Year | Code | Assessed | | | | | |
| HOLOTKA JOANNE | | 20342 0525 | 07-08-2014 | U | I | 100 | 1 | 2022 | 101 | 188,000 | 2021 | 101 | 180,600 | 2020 | 101 | 177,000 | | | | | |
| HOLOTKA ANTOINETTE HEIRS + DEV | | 04433 0303 | 06-09-1977 | U | I | 0 | | | 101 | 125,500 | | 101 | 117,500 | | 101 | 117,500 | | | | | |
| Total | | | | | | | | Total | | 313,500 | Total | | 298,100 | Total | | 294,500 | | | | | |
| EXEMPTIONS | | | | OTHER ASSESSMENTS | | | | This signature acknowledges a visit by a Data Collector or Assessor | | | | | | | | | | | | | |
| Year | Code | Description | Amount | Code | Description | YEAR | Amount | Comm Int | | | | | | | | | | | | | |
| Total | | | 0.00 | | | | | | | | | | | | | | | | | | |
| ASSESSING NEIGHBORHOOD | | | | | | | | APPRAISED VALUE SUMMARY | | | | | | | | | | | | | |
| Nbhd | Nbhd Name | | | Tracing | | | Batch | Appraised BLDG. Value (Card) 205,900 | | | | | | | | | | | | | |
| 0001 | | | | 101 | | | MG | Appraised Xf (B) Value (Bldg) 0 | | | | | | | | | | | | | |
| NOTES | | | | | | | | Appraised Ob (B) Value (Bldg) 0 | | | | | | | | | | | | | |
| | | | | | | | | Appraised Land Value (Bldg) 137,900 | | | | | | | | | | | | | |
| | | | | | | | | Special Land Value 0 | | | | | | | | | | | | | |
| | | | | | | | | Total Appraised Parcel Value 343,800 | | | | | | | | | | | | | |
| | | | | | | | | Valuation Method C | | | | | | | | | | | | | |
| | | | | | | | | Adjustment | | | | | | | | | | | | | |
| | | | | | | | | Net Total Appraised Parcel Value 343,800 | | | | | | | | | | | | | |
| BUILDING PERMIT RECORD | | | | | | | | VISIT / CHANGE HISTORY | | | | | | | | | | | | | |
| Permit Id | Issue Date | Type | Description | Amount | Insp Date | % Comp | Date Comp | Comments | Date | Type | Is | Id | Cd | Purpose/Result | | | | | | | |
| 392 | 11-30-2006 | 12 | REROOF | 5,000 | | | | NVC | 05-08-2018 | | | 333 | 2 | MEASURED | | | | | | | |
| | | | | | | | | | 02-19-2009 | | | 250 | 11 | ENTRY DENIED | | | | | | | |
| | | | | | | | | | 10-03-2008 | | | 317 | 2 | MEASURED | | | | | | | |
| | | | | | | | | | 02-23-2007 | | | 311 | 15 | PERMIT VISIT | | | | | | | |
| | | | | | | | | | 02-23-2007 | | | 311 | 15 | PERMIT VISIT | | | | | | | |
| | | | | | | | | | 10-10-2001 | | | 250 | 22 | MAILER SENT | | | | | | | |
| | | | | | | | | | 10-02-2001 | | | 247 | 2 | MEASURED | | | | | | | |
| LAND LINE VALUATION SECTION | | | | | | | | | | | | | | | | | | | | | |
| B | Use Co | Description | Zone | D | Fronta | Depth | Land Units | Unit Price | I. Fact | S.A. | Ac Di | C. Fact | St. Idx | Adj | Notes | Special Pricing | | | Size A | Adj Unit Pric | Land Value |
| 1 | 101 | ONE FAM | RA | | | | 40,000 SF | 2.84 | 1.200 | 7 | LAND | 1.00 | MG | 1.00 | | 0 | TRF2 | 0.9 | 1.000 | 3.07 | 122,800 |
| 1 | 101 | ONE FAM | RA | | | | 2.160 AC | 7,000.00 | 1.000 | 0 | | 1.00 | MG | 1.00 | | 0 | | | 1.000 | 7,000 | 15,100 |
| Total Card Land Units | | | | | | | 3.08 AC | Parcel Total Land Area: 3.08 | | | | | Total Land Value | | | | | 137,900 | | | |

| CONSTRUCTION DETAIL | | | CONSTRUCTION DETAIL (CONTINUED) | | |
|---------------------|------|-------------|---------------------------------|-------------|-------------|
| Element | Cd | Description | Element | Cd | Description |
| Style | 19 | RANCH | Basement Floor | | |
| Model | 01 | RESIDENTIAL | Bsmt Garage | | |
| Grade | C+ | AVG. (+) | #Heat Sys | 1.00 | |
| Stories | 1.00 | 1 STORY | Units | 1 | |
| Foundation | 1 | CONCRETE | MIXED USE | | |
| Exterior Wall 1 | 4 | VINYL | Code | Description | Percentage |
| Exterior Wall 2 | 16 | STONE VENR | 101 | ONE FAM | 100 |
| Roof Structure | 2 | HIP | | | 0 |
| Roof Cover | 1 | ASPHALT SH | | | 0 |
| Interior Wall 1 | 2 | PLASTER | COST / MARKET VALUATION | | |
| Interior Wall 2 | | | Adj Base Rate | | 108.38 |
| Interior Floor 1 | 3 | HARDWOOD | RCN | | 326,812 |
| Interior Floor 2 | | | Net Other Adj | | |
| Heat Fuel | 2 | GAS | Year Built | | 1978 |
| Heat Type | 1 | FORCED H/A | Effective Year Built | | 1984 |
| AC Type | 03 | FULL | Depreciation Code | | AV |
| Bedrooms | 3 | | Remodel Rating | | |
| Full Baths | 2 | | Year Remodeled | | |
| Half Baths | 1 | | Depreciation % | | 37 |
| Extra Fixtures | 3 | | Functional Obsol | | |
| Total Rooms | 7 | | External Obsol | | |
| Bath Style | A | AVERAGE | Cost Trend Factor | | 1 |
| Half Bath Style | A | AVERAGE | Condition | | |
| Kitchens | 1 | | % Complete | | |
| Kitchen Style | A | AVERAGE | Overall % Condition | | 63 |
| Extra Kitchens | 0 | | RCNLD | | 205,900 |
| Extra Kitchen St | | | Dep % Ovr | | |
| FBM Sqft | 800 | | Dep Ovr Comment | | |
| FBM Quality | 1 | | Misc Imp Ovr | | |
| Fireplaces | 2 | | Misc Imp Ovr Comment | | |
| WS Flues | | | Cost to Cure Ovr | | |
| Central Vac | 1 | YES | Cost to Cure Ovr Comment | | |
| Frame | 1 | WOOD | | | |

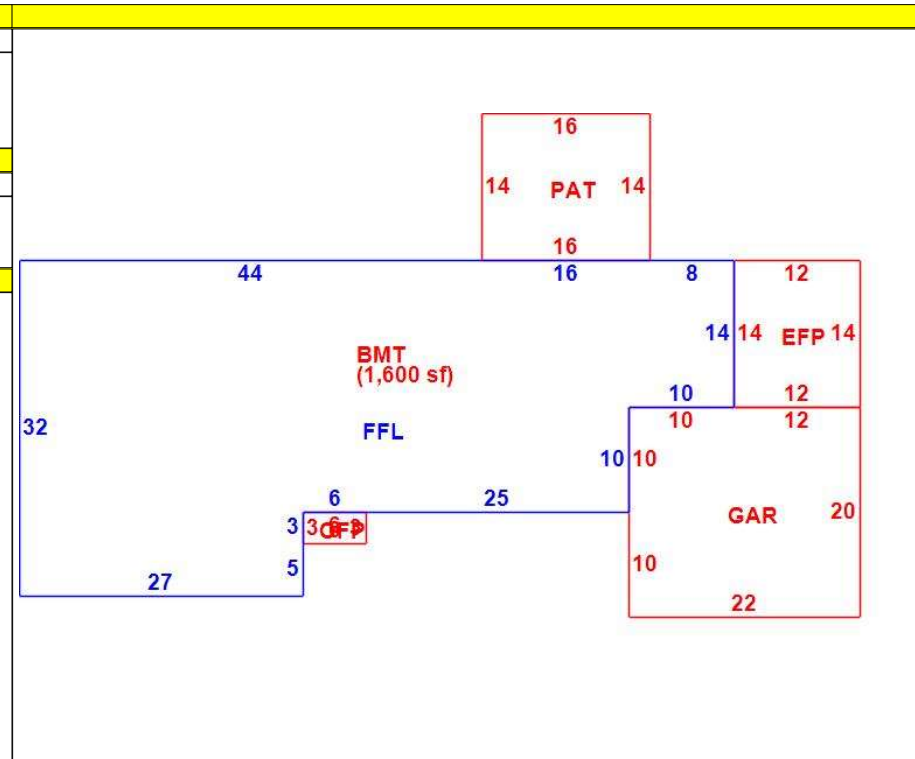

| OB - OUTBUILDING & YARD ITEMS(L) / XF - BUILDING EXTRA FEATURES(B) | | | | | | | | | | | | | |
|--|-------------|----|----------|-----|-------|------------|--------|---|------|------|-----|------|------------|
| Code | Description | Su | Sub Type | Lan | Units | Unit Price | Yr Blt | % | Dep. | Cond | Gra | Qual | Apprais Va |
| | | | | | | | | | | | | | |

| BUILDING SUB-AREA SUMMARY SECTION | | | | | | | |
|-----------------------------------|-------------|--------|-------|----------|-----------|----------------|--|
| Subarea | Description | Living | Gross | Eff Area | Unit Cost | Undeprec Value | |
| BMT | BASEMENT | 0 | 1,600 | | 27.92 | 44,673 | |
| EFP | ENCL PORCH | 0 | 168 | | 69.80 | 11,727 | |
| FFL | 1ST FLOOR | 1,748 | 1,748 | | 139.60 | 244,027 | |
| GAR | GARAGE | 0 | 440 | | 55.84 | 24,570 | |
| OPF | OPEN PORCH | 0 | 18 | | 15.51 | 279 | |
| PAT | PATIO | 0 | 224 | | 6.86 | 1,536 | |
| Ttl Gross Liv / Lease Area | | 1,748 | 4,198 | | | 326,812 | |

