

CURRENT OWNER		TOPO TYPE	UTILITY	STREET	LOCATION	CURRENT ASSESSMENT				
HENDERSON NEIL T HENDERSON CAROLENE R 88 DAY AVE EAST LONGMEADOW MA 01028						Description	Code	Appraised	Assessed	1006 EAST LONGMEADOW
		TOPO WET	EASEMENT	TRAFFIC	CORNER	RESIDNTL.	101	216900	216,900	
		DRAINAGE		VIEW	COMMUNITY	RES LAND	101	113100	113,100	
						RESIDNTL.	101	2800	2,800	
SUPPLEMENTAL DATA						Total		332,800	332,800	
Alt Prcl ID SP Permit Chapter Land OC Dates In+Ex FY Mailed				Received NIA Field 8 Field 9 Field 10 Assoc Pid#						
GIS ID F_380556_2854906										

RECORD OF OWNERSHIP		BK-VOL/PAGE	SALE DATE	Q/U	V/I	SALE PRICE	VC	PREVIOUS ASSESSMENTS (HISTORY)								
HENDERSON NEIL T		11777	0195	07-27-2001	U	I	185,000	Year	Code	Assessed	Year	Code	Assessed	Year	Code	Assessed
DUFFY CAROLA+,		06178	0225	08-04-1986	U	I	1	2023	101	199,600	2022	101	177,900	2021	101	170,700
		05466	0019	07-14-1983	U	I	0		101	102,900		101	93,600		101	86,700
									101	2,000		101	2,000		101	2,000
		Total						Total		304,500	Total		273,500	Total		259,400

EXEMPTIONS				OTHER ASSESSMENTS				This signature acknowledges a visit by a Data Collector or Assessor				
Year	Code	Description	Amount	Code	Description	YEAR	Amount	Comm Int				
Total												

ASSESSING NEIGHBORHOOD				APPRAISED VALUE SUMMARY			
Nbhd	Nbhd Name	Tracing	Batch				
0001		101	MA				
NOTES				NET TOTAL APPRAISED PARCEL VALUE			
				332,800			

BUILDING PERMIT RECORD										VISIT / CHANGE HISTORY					
Permit Id	Issue Date	Type	Description	Amount	Insp Date	% Comp	Date Comp	Comments	Date	Type	Is	Id	Cd	Purpose/Result	
165	06-27-2001	20	WOOD STOVE	200				COAL STOVE	10-31-2014			317	14	INSPECTED	
191	01-01-1986	MN	Manual Note					FAM ROOM	10-24-2014			317	2	MEASURED	
169	01-01-1986	MN	Manual Note					DEMO	11-15-2003			274	3	MEAS+INSPCTD	
									02-07-2002			274	15	PERMIT VISIT	
									06-03-1992			131	3	MEAS+INSPCTD	
									04-27-1992			107	22	MAILER SENT	
									08-31-1991			131	2	MEASURED	

LAND LINE VALUATION SECTION																					
B	Use Co	Description	Zone	D	Fronta	Depth	Land Units	Unit Price	I. Fact	S.A.	Ac Di	C. Fact	St. Idx	Adj	Notes	Special Pricing			Size A	Adj Unit Pric	Land Value
1	101	ONE FAM	RB				15,000	SF	7.54	1.000	5	LAND	1.00	MA	1.00		0		1.000	7.54	113,100
Total Card Land Units							0.34	AC	Parcel Total Land Area:			0.34								Total Land Value	113,100

CONSTRUCTION DETAIL			CONSTRUCTION DETAIL (CONTINUED)		
Element	Cd	Description	Element	Cd	Description
Style	19	RANCH	Basement Floor	12	CONCRETE
Model	01	RESIDENTIAL	Bsmt Garage		
Grade	C	AVERAGE	#Heat Sys	1.00	
Stories	1.00	1 STORY	Units	1	
Foundation	1	CONCRETE	MIXED USE		
Exterior Wall 1	4	VINYL	Code	Description	Percentage
Exterior Wall 2	8	BRICK VENR	101	ONE FAM	100
Roof Structure	1	GABLE			0
Roof Cover	1	ASPHALT SH			0
Interior Wall 1	1	DRYWALL	COST / MARKET VALUATION		
Interior Wall 2			Adj Base Rate		116.54
Interior Floor 1	3	HARDWOOD	RCN		344,304
Interior Floor 2	4	CARPET	Net Other Adj		
Heat Fuel	2	GAS	Year Built		1958
Heat Type	1	FORCED H/A	Effective Year Built		1984
AC Type	03	FULL	Depreciation Code		AG
Bedrooms	3		Remodel Rating		
Full Baths	2		Year Remodeled		
Half Baths	0		Depreciation %		37
Extra Fixtures	1		Functional Obsol		
Total Rooms	6		External Obsol		
Bath Style	A	AVERAGE	Cost Trend Factor		1
Half Bath Style			Condition		
Kitchens	1		% Complete		
Kitchen Style	A	AVERAGE	Overall % Condition		63
Extra Kitchens	0		RCNLD		216,900
Extra Kitchen St			Dep % Ovr		
FBM Sqft	1045		Dep Ovr Comment		
FBM Quality	3		Misc Imp Ovr		
Fireplaces	1		Misc Imp Ovr Comment		
WS Flues	1		Cost to Cure Ovr		
Central Vac	1	YES	Cost to Cure Ovr Comment		
Frame	1	WOOD			

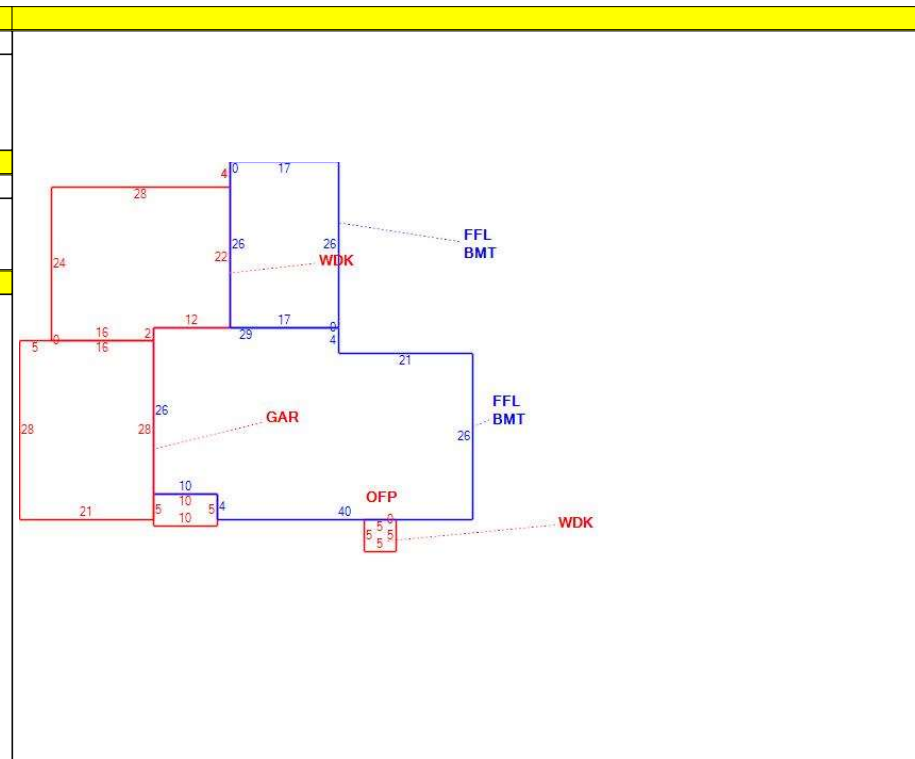

OB - OUTBUILDING & YARD ITEMS(L) / XF - BUILDING EXTRA FEATURES(B)													
Code	Description	Su	Sub Type	Lan	Units	Unit Price	Yr Blt	%	Dep.	Cond	Gra	Qual	Apprais Va
02	SHED/FR			L	288	12.00	1984	60	0.00	AV	A	1.00	2,100
07	POOLA-C	OB	Outbuildi	L	18	69.00	2005	60	0.00	AV	A	1.00	700

BUILDING SUB-AREA SUMMARY SECTION							
Subarea	Description	Living	Gross	Eff Area	Unit Cost	Undeprec Value	
BMT	BASEMENT	0	1,818		26.96	49,013	
FFL	1ST FLOOR	1,818	1,818		134.65	244,796	
GAR	GARAGE	0	588		53.81	31,643	
OFF	OPEN PORCH	0	50		13.47	673	
WDK	WOOD DECK	0	673		27.01	18,178	
Ttl Gross Liv / Lease Area		1,818	4,947			344,304	

