

| CURRENT OWNER | | TOPO TYPE | UTILITY | STREET | LOCATION | CURRENT ASSESSMENT | | | | |
|--------------------------|--|------------|----------|---------|-----------|--------------------|------|-----------|----------|-------------------------|
| DEMAIO AMBER M | | | | | | Description | Code | Appraised | Assessed | 1006 EAST LONGMEADOW |
| 5 REVERE ST | | TOPO WET | EASEMENT | TRAFFIC | CORNER | RESIDNTL. | 101 | 102000 | 102,000 | |
| EAST LONGMEADOW MA 01028 | | DRAINAGE | | VIEW | COMMUNITY | RES LAND | 101 | 89700 | 89,700 | |
| GIS ID F_382510_2855969 | | | | | | RESIDNTL. | 101 | 8900 | 8,900 | |
| SUPPLEMENTAL DATA | | | | | | Total | | 200,600 | 200,600 | |
| Alt Prcl ID | | Received | | | | | | | | |
| SP Permit | | NIA | | | | | | | | |
| Chapter Land | | Field 8 | | | | | | | | |
| OC Dates | | Field 9 | | | | | | | | |
| In+Ex FY | | Field 10 | | | | | | | | |
| Mailed | | Assoc Pid# | | | | | | | | |

| RECORD OF OWNERSHIP | | BK-VOL/PAGE | SALE DATE | Q/U | V/I | SALE PRICE | VC | PREVIOUS ASSESSMENTS (HISTORY) | | | | | | | | |
|---------------------|-------|-------------|------------|-----|-----|------------|----|--------------------------------|------|----------|------|---------|----------|-------|------|----------|
| DEMAIO AMBER M | 24399 | 0396 | 02-09-2022 | Q | I | 220,000 | 00 | Year | Code | Assessed | Year | Code | Assessed | Year | Code | Assessed |
| HINDES CARL R JR | 10503 | 0068 | 10-29-1998 | U | I | 1 | 1A | 2023 | 101 | 93,700 | 2022 | 101 | 83,700 | 2021 | 101 | 80,400 |
| HINDES,CARL R JR | 06947 | 0597 | 08-29-1988 | U | I | 1 | 1A | | 101 | 81,300 | | 101 | 74,000 | | 101 | 68,500 |
| HINDES | 02371 | 0284 | 02-28-1955 | U | I | 0 | | | 101 | 7,500 | | 101 | 7,500 | | 101 | 7,500 |
| Total | | | | | | | | 182,500 | | Total | | 165,200 | | Total | | 156,400 |

| EXEMPTIONS | | | | OTHER ASSESSMENTS | | | | This signature acknowledges a visit by a Data Collector or Assessor | | | | | | | | | | |
|------------|------|-------------|--------|-------------------|-------------|------|--------|---|--|--|--|--|--|--|--|--|--|--|
| Year | Code | Description | Amount | Code | Description | YEAR | Amount | Comm Int | | | | | | | | | | |
| | | | | | | | | | | | | | | | | | | |
| Total | | | | | | | | | | | | | | | | | | |

| ASSESSING NEIGHBORHOOD | | | | | | APPRAISED VALUE SUMMARY | | | | | | | | | |
|------------------------|-----------|--|---------|--|-------|----------------------------------|--|--|--|--|---------|--|--|--|--|
| Nbhd | Nbhd Name | | Tracing | | Batch | Appraised BLDG. Value (Card) | | | | | 102,000 | | | | |
| 0001 | | | 101 | | MF | Appraised Xf (B) Value (Bldg) | | | | | 0 | | | | |
| | | | | | | Appraised Ob (B) Value (Bldg) | | | | | 8,900 | | | | |
| | | | | | | Appraised Land Value (Bldg) | | | | | 89,700 | | | | |
| | | | | | | Special Land Value | | | | | 0 | | | | |
| | | | | | | Total Appraised Parcel Value | | | | | 200,600 | | | | |
| | | | | | | Valuation Method | | | | | C | | | | |
| | | | | | | Adjustment | | | | | | | | | |
| | | | | | | Net Total Appraised Parcel Value | | | | | 200,600 | | | | |

| BUILDING PERMIT RECORD | | | | | | | | | | VISIT / CHANGE HISTORY | | | | | |
|------------------------|------------|------|-------------|--------|-----------|--------|-----------|----------|--|------------------------|------|----|-----|----|----------------|
| Permit Id | Issue Date | Type | Description | Amount | Insp Date | % Comp | Date Comp | Comments | | Date | Type | Is | Id | Cd | Purpose/Result |
| | | | | | | | | | | 09-25-2015 | | | 317 | 2 | MEASURED |
| | | | | | | | | | | 08-23-2003 | | | 274 | 3 | MEAS+INSPCTD |
| | | | | | | | | | | 02-18-1992 | | | 170 | 3 | MEAS+INSPCTD |
| | | | | | | | | | | 12-15-1980 | | | 500 | 3 | MEAS+INSPCTD |

| LAND LINE VALUATION SECTION | | | | | | | | | | | | | | | | | | | | | |
|-----------------------------|--------|-------------|------|---|--------|-------|------------|------------|------------------------------|------|-------|---------|------------------|------|-------|-----------------|--|--|--------|---------------|------------|
| B | Use Co | Description | Zone | D | Fronta | Depth | Land Units | Unit Price | I. Fact | S.A. | Ac Di | C. Fact | St. Idx | Adj | Notes | Special Pricing | | | Size A | Adj Unit Pric | Land Value |
| 1 | 101 | ONE FAM | RA | | | | 25,263 SF | 4.67 | 0.760 | 3 | LAND | 1.00 | MF | 1.00 | | 0 | | | 1.000 | 3.55 | 89,700 |
| Total Card Land Units | | | | | | | 0.58 | AC | Parcel Total Land Area: 0.58 | | | | Total Land Value | | | | | | | 89,700 | |

| CONSTRUCTION DETAIL | | | CONSTRUCTION DETAIL (CONTINUED) | | |
|---------------------|------|---------------|---------------------------------|-------------|-------------|
| Element | Cd | Description | Element | Cd | Description |
| Style | 02 | BUNGALOW | Basement Floor | 12 | CONCRETE |
| Model | 01 | RESIDENTIAL | Bsmt Garage | | |
| Grade | C- | AVG. (-) | #Heat Sys | 1.00 | |
| Stories | 1.50 | 1 1/2 STORIES | Units | 1 | |
| Foundation | 3 | MASONRY | MIXED USE | | |
| Exterior Wall 1 | 1 | WOOD SHING | Code | Description | Percentage |
| Exterior Wall 2 | | | 101 | ONE FAM | 100 |
| Roof Structure | 1 | GABLE | | | 0 |
| Roof Cover | 1 | ASPHALT SH | | | 0 |
| Interior Wall 1 | 6 | AVERAGE | COST / MARKET VALUATION | | |
| Interior Wall 2 | | | Adj Base Rate | | 118.71 |
| Interior Floor 1 | 3 | HARDWOOD | RCN | | 178,996 |
| Interior Floor 2 | 4 | CARPET | Net Other Adj | | |
| Heat Fuel | 1 | OIL | Year Built | | 1943 |
| Heat Type | 1 | FORCED H/A | Effective Year Built | | 1978 |
| AC Type | 03 | FULL | Depreciation Code | | AV |
| Bedrooms | 3 | | Remodel Rating | | |
| Full Baths | 1 | | Year Remodeled | | |
| Half Baths | 0 | | Depreciation % | | 43 |
| Extra Fixtures | 0 | | Functional Obsol | | |
| Total Rooms | 5 | | External Obsol | | |
| Bath Style | A | AVERAGE | Cost Trend Factor | | 1 |
| Half Bath Style | | | Condition | | |
| Kitchens | 1 | | % Complete | | |
| Kitchen Style | A | AVERAGE | Overall % Condition | | 57 |
| Extra Kitchens | 0 | | RCNLD | | 102,000 |
| Extra Kitchen St | | | Dep % Ovr | | |
| FBM Sqft | | | Dep Ovr Comment | | |
| FBM Quality | | | Misc Imp Ovr | | |
| Fireplaces | 0 | | Misc Imp Ovr Comment | | |
| WS Flues | | | Cost to Cure Ovr | | |
| Central Vac | 0 | NO | Cost to Cure Ovr Comment | | |
| Frame | 1 | WOOD | | | |

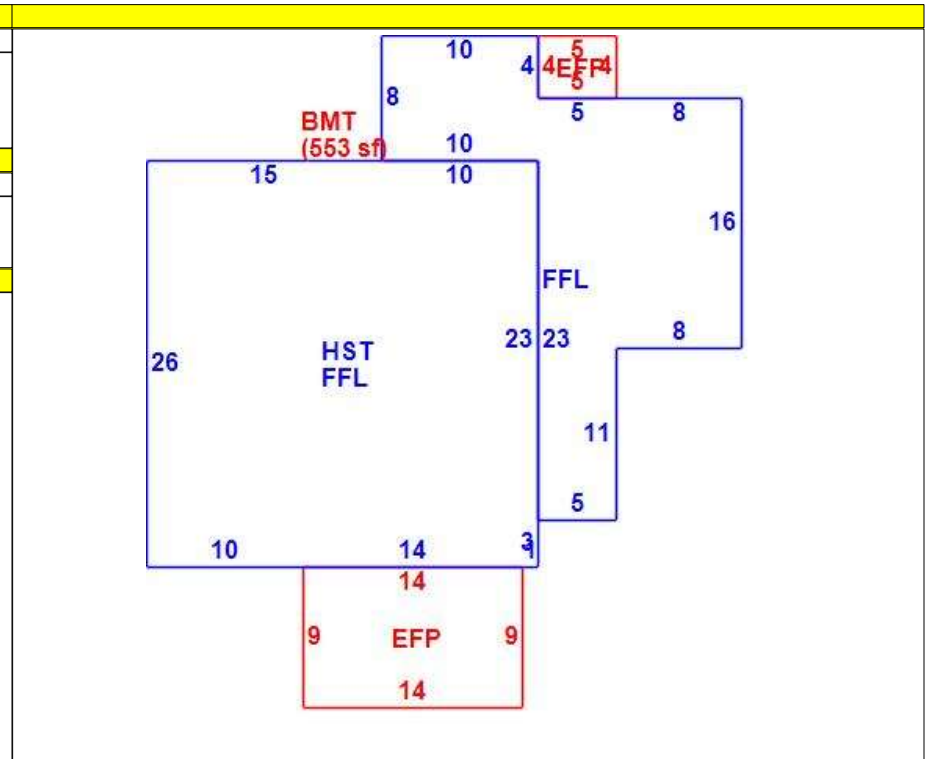

| OB - OUTBUILDING & YARD ITEMS(L) / XF - BUILDING EXTRA FEATURES(B) | | | | | | | | | | | | | |
|--|-------------|----|-----------|-----|-------|------------|--------|----|------|------|-----|------|------------|
| Code | Description | Su | Sub Type | Lan | Units | Unit Price | Yr Blt | % | Dep. | Cond | Gra | Qual | Apprais Va |
| 03 | GARAGE | OB | Outbuildi | L | 405 | 32.00 | 1953 | 60 | 0.00 | AV | A | 1.00 | 7,800 |
| 02 | SHED/FR | | | L | 180 | 12.00 | 1953 | 50 | 0.00 | FR | A | 1.00 | 1,100 |

| BUILDING SUB-AREA SUMMARY SECTION | | | | | | |
|-----------------------------------|-------------|--------|-------|----------|-----------|----------------|
| Subarea | Description | Living | Gross | Eff Area | Unit Cost | Undeprec Value |
| BMT | BASEMENT | 0 | 553 | | 23.92 | 13,228 |
| EFP | ENCL PORCH | 0 | 146 | | 59.59 | 8,700 |
| FFL | 1ST FLOOR | 993 | 993 | | 119.17 | 118,338 |
| HST | HALF STORY | 325 | 650 | | 59.59 | 38,731 |
| Ttl Gross Liv / Lease Area | | 1,318 | 2,342 | | | 178,996 |

