

CONSTRUCTION DETAIL			CONSTRUCTION DETAIL (CONTINUED)		
Element	Cd	Description	Element	Cd	Description
Style	06	COLONIAL	Basement Floor	12	CONCRETE
Model	01	RESIDENTIAL	Bsmt Garage		
Grade	C	AVERAGE	#Heat Sys	1.00	
Stories	2.00	2 STORY	Units	1	
Foundation	1	CONCRETE	MIXED USE		
Exterior Wall 1	2	CLAPBOARD	Code	Description	
Exterior Wall 2	9	STONE	101	ONE FAM	100
Roof Structure	3	GAMBREL			0
Roof Cover	1	ASPHALT SH			0
Interior Wall 1	5	MINIMUM	COST / MARKET VALUATION		
Interior Wall 2	1	DRYWALL	Adj Base Rate	129.60	
Interior Floor 1	1	PLYWOOD	RCN	255,354	
Interior Floor 2	5	LINO/VINYL	Net Other Adj		
Heat Fuel	2	GAS	Year Built	1974	
Heat Type	3	FORCED H/W	Effective Year Built	1969	
AC Type	01	NONE	Depreciation Code	FR	
Bedrooms	3		Remodel Rating		
Full Baths	0		Year Remodeled		
Half Baths	0		Depreciation %	52	
Extra Fixtures	2		Functional Obsol	20	
Total Rooms	7		External Obsol		
Bath Style			Cost Trend Factor	1	
Half Bath Style			Condition		
Kitchens	1		% Complete		
Kitchen Style	A	AVERAGE	Overall % Condition	28	
Extra Kitchens	0		RCNLD	71,500	
Extra Kitchen St			Dep % Ovr		
FBM Sqft			Dep Ovr Comment		
FBM Quality			Misc Imp Ovr		
Fireplaces	2		Misc Imp Ovr Comment		
WS Flues			Cost to Cure Ovr		
Central Vac	0	NO	Cost to Cure Ovr Comment		
Frame	1	WOOD			

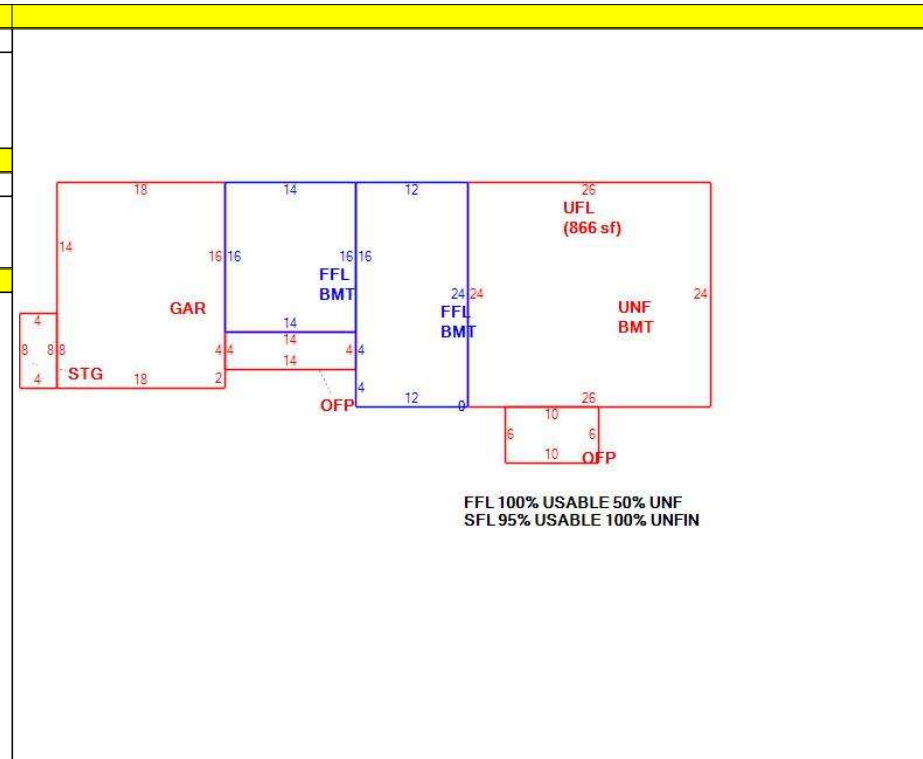

OB - OUTBUILDING & YARD ITEMS(L) / XF - BUILDING EXTRA FEATURES(B)													
Code	Description	Su	Sub Type	Lan	Units	Unit Price	Yr Blt	%	Dep.	Cond	Gra	Qual	Apprais Va
11	POOL I-V	OB	Outbuildi	L	512	29.00	1980	10	0.00	DL	D	0.60	0

BUILDING SUB-AREA SUMMARY SECTION							
Subarea	Description	Living	Gross	Eff Area	Unit Cost	Undeprec Value	
BMT	BASEMENT	0	1,136		28.10	31,919	
FFL	1ST FLOOR	512	512		140.61	71,994	
GAR	GARAGE	0	396		56.10	22,217	
OFF	OPEN PORCH	0	116		14.55	1,687	
STG	STORAGE	0	32		57.12	1,828	
UFL	UNFIN UPFR FLOOR	0	866		84.43	73,119	
UNF	UNFIN FIRST FLR	0	624		84.28	52,589	
Ttl Gross Liv / Lease Area		512	3,682			255,354	

