

CURRENT OWNER		TOPO TYPE	UTILITY	STREET	LOCATION	CURRENT ASSESSMENT				
GRIMALDI FRANCIS J TR GRIMALDI JUDITH A TR 44 PIONEER CR EAST LONGMEADOW MA 01028						Description	Code	Appraised	Assessed	1006 EAST LONGMEADOW
		TOPO WET	EASEMENT	TRAFFIC	CORNER	RESIDNTL.	101	178300	178,300	
		DRAINAGE		VIEW	COMMUNITY	RES LAND	101	117800	117,800	
						RESIDNTL.	101	800	800	
SUPPLEMENTAL DATA						Total		296,900	296,900	
GIS ID F_392580_2852381		Alt Prcl ID SP Permit Chapter Land OC Dates In+Ex FY Mailed		Received NIA Field 8 Field 9 Field 10 Assoc Pid#						

RECORD OF OWNERSHIP		BK-VOL/PAGE	SALE DATE	Q/U	V/I	SALE PRICE	VC	PREVIOUS ASSESSMENTS (HISTORY)									
GRIMALDI FRANCIS J TR		22852	0235	09-13-2019	U	I	100	1A	Year	Code	Assessed	Year	Code	Assessed	Year	Code	Assessed
GRIMALDI FRANCIS J		03236	0289	01-09-1967	U	I	0		2023	101	163,800	2022	101	144,100	2021	101	138,200
										101	107,000		101	97,300		101	90,000
										101	500		101	500		101	500
									Total		271,300	Total		241,900	Total		228,700

EXEMPTIONS				OTHER ASSESSMENTS				This signature acknowledges a visit by a Data Collector or Assessor										
Year	Code	Description	Amount	Code	Description	YEAR	Amount	Comm Int										
			Total															

ASSESSING NEIGHBORHOOD						APPRAISED VALUE SUMMARY									
Nbhd	Nbhd Name		Tracing		Batch										
0001			101		MA										
NOTES															
										Appraised BLDG. Value (Card)		178,300			
										Appraised Xf (B) Value (Bldg)		0			
										Appraised Ob (B) Value (Bldg)		800			
										Appraised Land Value (Bldg)		117,800			
										Special Land Value		0			
										Total Appraised Parcel Value		296,900			
										Valuation Method		C			
										Adjustment					
										Net Total Appraised Parcel Value		296,900			

BUILDING PERMIT RECORD										VISIT / CHANGE HISTORY					
Permit Id	Issue Date	Type	Description	Amount	Insp Date	% Comp	Date Comp	Comments		Date	Type	Is	Id	Cd	Purpose/Result
201903020	10-07-2019	91	INSULATION	5,000		0				05-08-2018			333	2	MEASURED
										06-30-2005			274	14	INSPECTED
										06-23-2005			274	2	MEASURED
										12-02-1999			247	3	MEAS+INSPCTD
										06-30-1991			131	3	MEAS+INSPCTD
										12-23-1980			500	3	MEAS+INSPCTD

LAND LINE VALUATION SECTION																					
B	Use Co	Description	Zone	D	Fronta	Depth	Land Units	Unit Price	I. Fact	S.A.	Ac Di	C. Fact	St. Idx	Adj	Notes	Special Pricing			Size A	Adj Unit Pric	Land Value
1	101	ONE FAM	RA				25,000 SF	4.71	1.000	5	LAND	1.00	MA	1.00			0		1.000	4.71	117,800
Total Card Land Units							0.57	AC	Parcel Total Land Area:			0.57								Total Land Value	117,800

CONSTRUCTION DETAIL			CONSTRUCTION DETAIL (CONTINUED)		
Element	Cd	Description	Element	Cd	Description
Style	19	RANCH	Basement Floor	5	LINO/VINYL
Model	01	RESIDENTIAL	Bsmt Garage		
Grade	C	AVERAGE	#Heat Sys	1.00	
Stories	1.00	1 STORY	Units	1	
Foundation	1	CONCRETE	MIXED USE		
Exterior Wall 1	4	VINYL	Code	Description	Percentage
Exterior Wall 2			101	ONE FAM	100
Roof Structure	1	GABLE			0
Roof Cover	1	ASPHALT SH			0
Interior Wall 1	2	PLASTER	COST / MARKET VALUATION		
Interior Wall 2			Adj Base Rate		125.82
Interior Floor 1	4	CARPET	RCN		282,973
Interior Floor 2	10	PARQUET	Net Other Adj		
Heat Fuel	2	GAS	Year Built		1955
Heat Type	3	FORCED H/W	Effective Year Built		1984
AC Type	01	NONE	Depreciation Code		AG
Bedrooms	3		Remodel Rating		
Full Baths	2		Year Remodeled		
Half Baths	0		Depreciation %		37
Extra Fixtures	0		Functional Obsol		
Total Rooms	6		External Obsol		
Bath Style	A	AVERAGE	Cost Trend Factor		1
Half Bath Style			Condition		
Kitchens	1		% Complete		
Kitchen Style	A	AVERAGE	Overall % Condition		63
Extra Kitchens	0		RCNLD		178,300
Extra Kitchen St			Dep % Ovr		
FBM Sqft	996		Dep Ovr Comment		
FBM Quality	1		Misc Imp Ovr		
Fireplaces	1		Misc Imp Ovr Comment		
WS Flues			Cost to Cure Ovr		
Central Vac	1	YES	Cost to Cure Ovr Comment		
Frame	1	WOOD			

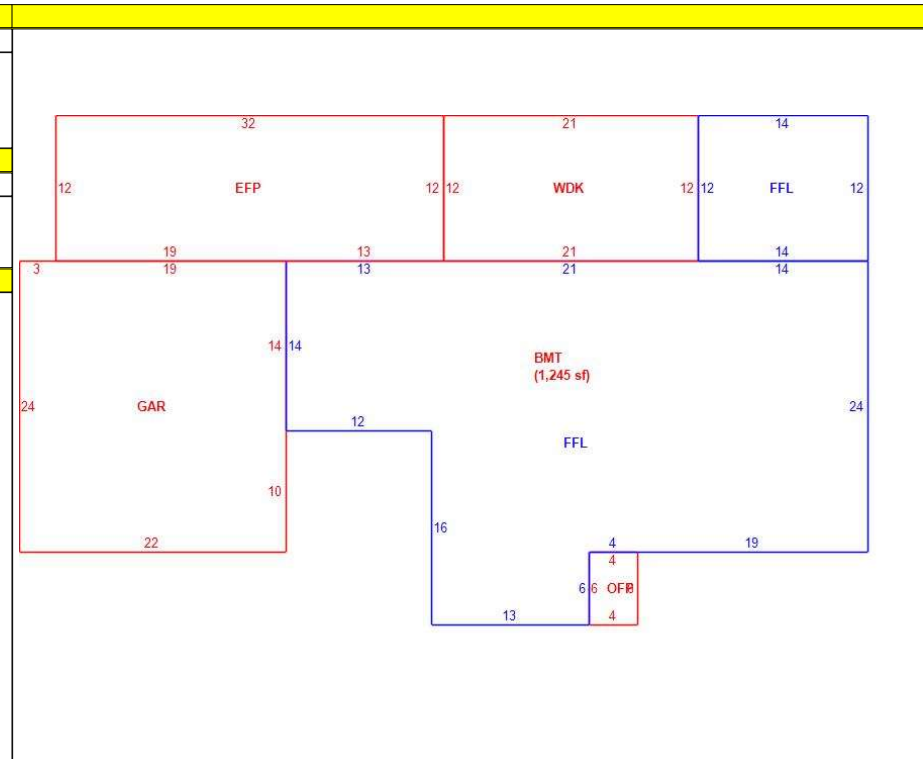

OB - OUTBUILDING & YARD ITEMS(L) / XF - BUILDING EXTRA FEATURES(B)													
Code	Description	Su	Sub Type	Lan	Units	Unit Price	Yr Blt	%	Dep.	Cond	Gra	Qual	Apprais Va
02	SHED/FR			L	112	12.00	1989	60	0.00	AV	A	1.00	800

BUILDING SUB-AREA SUMMARY SECTION							
Subarea	Description	Living	Gross	Eff Area	Unit Cost	Undeprec Value	
BMT	BASEMENT	0	1,245		28.55	35,550	
EFP	ENCL PORCH	0	384		71.39	27,412	
FFL	1ST FLOOR	1,278	1,278		142.77	182,462	
GAR	GARAGE	0	528		57.05	30,125	
OPF	OPEN PORCH	0	24		11.90	286	
WDK	WOOD DECK	0	252		28.33	7,139	
Ttl Gross Liv / Lease Area		1,278	3,711			282,973	

