

CURRENT OWNER		TOPO TYPE	UTILITY	STREET	LOCATION	CURRENT ASSESSMENT				
ATKINSON MARYANN TUROWSKY CHRISTOPHER 30 FERNWOOD DR EAST LONGMEADOW MA 01028						Description	Code	Appraised	Assessed	1006 EAST LONGMEADOW
		TOPO WET	EASEMENT	TRAFFIC	CORNER	RESIDNTL.	101	234200	234,200	
		DRAINAGE		VIEW	COMMUNITY	RES LAND	101	134300	134,300	
		SUPPLEMENTAL DATA				Received NIA Field 8 Field 9 Field 10 Assoc Pid#				
GIS ID F_390134_2849548		Mailed				Total	368,500	368,500		

RECORD OF OWNERSHIP		BK-VOL/PAGE	SALE DATE	Q/U	V/I	SALE PRICE	VC	PREVIOUS ASSESSMENTS (HISTORY)									
ATKINSON MARYANN		24964	0559	04-07-2023	Q	I	360,000	00	Year	Code	Assessed	Year	Code	Assessed	Year	Code	Assessed
WAKEBY DEVELOPMENT INC		24059	0401	08-13-2021	U	I	186,000	1L	2024	101	216,400	2023	101	139,900	2022	101	126,600
US BANK TRUST NATIONAL ASSOC TRUST		02900	0343	08-29-1962	Q	I	0	00		101	134,300		101	122,000		101	110,000
									Total	350,700	Total	261,900	Total	236,600			

EXEMPTIONS			OTHER ASSESSMENTS				This signature acknowledges a visit by a Data Collector or Assessor											
Year	Code	Description	Amount	Code	Description	YEAR	Amount	Comm Int										
		Total																

ASSESSING NEIGHBORHOOD				APPRAISED VALUE SUMMARY									
Nbhd	Nbhd Name	Tracing	Batch										
0001		101	MG										
NOTES				Appraised BLDG. Value (Card) 234,200 Appraised Xf (B) Value (Bldg) 0 Appraised Ob (B) Value (Bldg) 0 Appraised Land Value (Bldg) 134,300 Special Land Value 0 Total Appraised Parcel Value 368,500 Valuation Method C Adjustment Net Total Appraised Parcel Value 368,500									

BUILDING PERMIT RECORD									VISIT / CHANGE HISTORY						
Permit Id	Issue Date	Type	Description	Amount	Insp Date	% Comp	Date Comp	Comments	Date	Type	Is	Id	Cd	Purpose/Result	
202102943	10-04-2021	8	RENOVATION	48,800	06-30-2022	100	09-28-2022	AC-WINS, DRS, SID	06-09-2022			334	15	PERMIT VISIT	
									06-27-2018			333	2	MEASURED	
									12-06-2007			250	22	MAILER SENT	
									05-31-2007			311	2	MEASURED	
									10-01-2001			250	22	MAILER SENT	
									05-13-2000			247	2	MEASURED	
									07-01-1992			190	1	LEFT NOTICE	

LAND LINE VALUATION SECTION																					
B	Use Co	Description	Zone	D	Fronta	Depth	Land Units	Unit Price	I. Fact	S.A.	Ac Di	C. Fact	St. Idx	Adj	Notes	Special Pricing			Size A	Adj Unit Pric	Land Value
1	101	ONE FAM	RA				25,000 SF	4.71	1.200	7	LAND	0.95	MG	1.00	ESM1		0		1.000	5.37	134,300
Total Card Land Units							0.57	AC	Parcel Total Land Area:				0.57	Total Land Value					134,300		

CONSTRUCTION DETAIL			CONSTRUCTION DETAIL (CONTINUED)		
Element	Cd	Description	Element	Cd	Description
Style	19	RANCH	Central Vac	0	NO
Model	01	RESIDENTIAL	Basement Floor	12	CONCRETE
Grade	C+	AVG. (+)	Bsmt Garage	0	
Stories	1.00	1 STORY	Units	1	
Foundation	1	CONCRETE	MIXED USE		
Exterior Wall 1	4	VINYL	Code	Description	Percentage
Exterior Wall 2			101	ONE FAM	100
Roof Structure	2	HIP			0
Roof Cover	1	ASPHALT SH			0
Interior Wall 1	1	DRYWALL	COST / MARKET VALUATION		
Interior Wall 2			Adj Base Rate		149.75
Interior Floor 1	3	HARDWOOD	RCN		282,157
Interior Floor 2	6	CERAMIC TL	Net Other Adj		
Heat Fuel	2	GAS	Year Built		1956
Heat Type	1	FORCED H/A	Effective Year Built		2004
AC Type	03	FULL	Depreciation Code		VG
Bedrooms	3		Remodel Rating		04
Full Baths	1		Year Remodeled		2022
Half Baths	0		Depreciation %		17
Extra Fixtures	1		Functional Obsol		
Total Rooms	6		External Obsol		
Bath Style	G	GOOD	Cost Trend Factor		1
Half Bath Style	N	NONE	Condition		
Kitchens	1		% Complete		
Kitchen Style	G	GOOD	Overall % Condition		83
Extra Kitchens	0		RCNLD		234,200
Extra Kitchen St	N	NONE	Dep % Ovr		
FBM Sqft			Dep Ovr Comment		
FBM Quality			Misc Imp Ovr		
FIN ATC Sqft			Misc Imp Ovr Comment		
FIN ATC Quality			Cost to Cure Ovr		
Fireplaces	1		Cost to Cure Ovr Comment		
WS Flues	0				

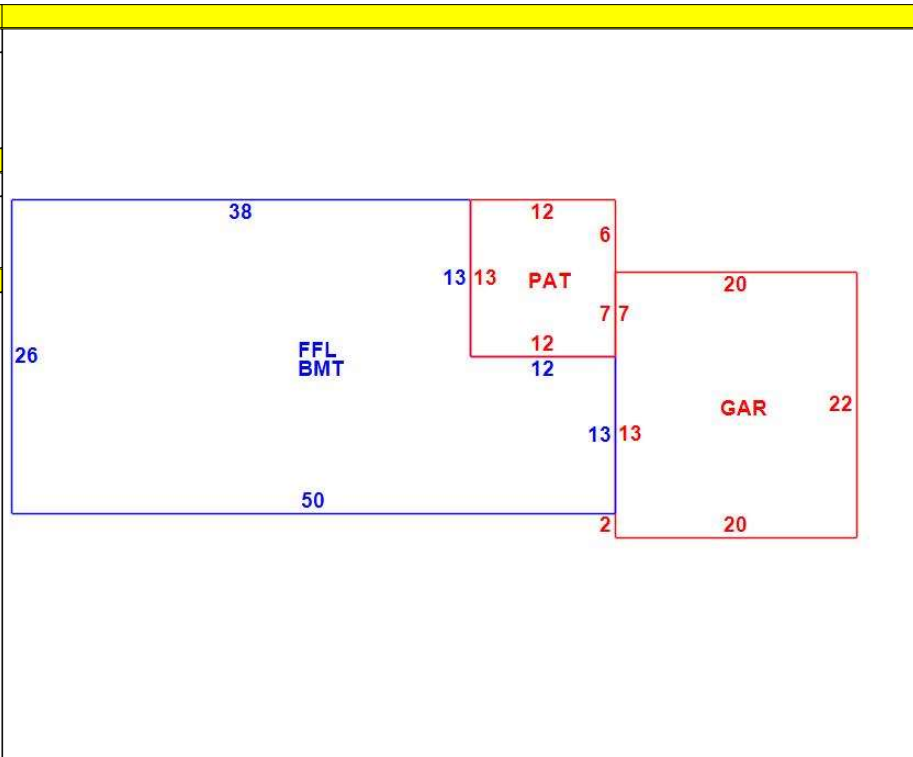

OB - OUTBUILDING & YARD ITEMS(L) / XF - BUILDING EXTRA FEATURES(B)													
Code	Description	Su	Sub Type	Lan	Units	Unit Price	Yr Blt	%	Dep.	Cond	Gra	Qual	Apprais Va

BUILDING SUB-AREA SUMMARY SECTION							
Subarea	Description	Living	Gross	Eff Area	Unit Cost	Undeprec Value	
BMT	BASEMENT	0	1,144		36.28	41,499	
FFL	1ST FLOOR	1,144	1,144		181.22	207,314	
GAR	GARAGE	0	440		72.49	31,894	
PAT	PATIO	0	156		9.29	1,450	
Ttl Gross Liv / Lease Area		1,144	2,884			282,157	

