

CONSTRUCTION DETAIL			CONSTRUCTION DETAIL (CONTINUED)		
Element	Cd	Description	Element	Cd	Description
Style	06	COLONIAL	Central Vac	0	NO
Model	01	RESIDENTIAL	Basement Floor	12	CONCRETE
Grade	C+	AVG. (+)	Bsmt Garage		
Stories	2.00	2 STORY	Units	1	
Foundation	1	CONCRETE	MIXED USE		
Exterior Wall 1	4	VINYL	Code	Description	Percentage
Exterior Wall 2	8	BRICK VENR	101	ONE FAM	100
Roof Structure	1	GABLE			0
Roof Cover	1	ASPHALT SH			0
Interior Wall 1	1	DRYWALL	COST / MARKET VALUATION		
Interior Wall 2			Adj Base Rate		120.17
Interior Floor 1	4	CARPET	RCN		455,538
Interior Floor 2			Net Other Adj		
Heat Fuel	2	GAS	Year Built		1979
Heat Type	1	FORCED H/A	Effective Year Built		1995
AC Type	01	NONE	Depreciation Code		GD
Bedrooms	4		Remodel Rating		
Full Baths	2		Year Remodeled		
Half Baths	1		Depreciation %		26
Extra Fixtures	0		Functional Obsol		
Total Rooms	9		External Obsol		
Bath Style	G	GOOD	Cost Trend Factor		1
Half Bath Style	G	GOOD	Condition		
Kitchens	1		% Complete		
Kitchen Style	G	GOOD	Overall % Condition		74
Extra Kitchens	0		RCNLD		337,100
Extra Kitchen St			Dep % Ovr		
FBM Sqft			Dep Ovr Comment		
FBM Quality			Misc Imp Ovr		
FIN ATC Sqft			Misc Imp Ovr Comment		
FIN ATC Quality			Cost to Cure Ovr		
Fireplaces	1		Cost to Cure Ovr Comment		
WS Flues					

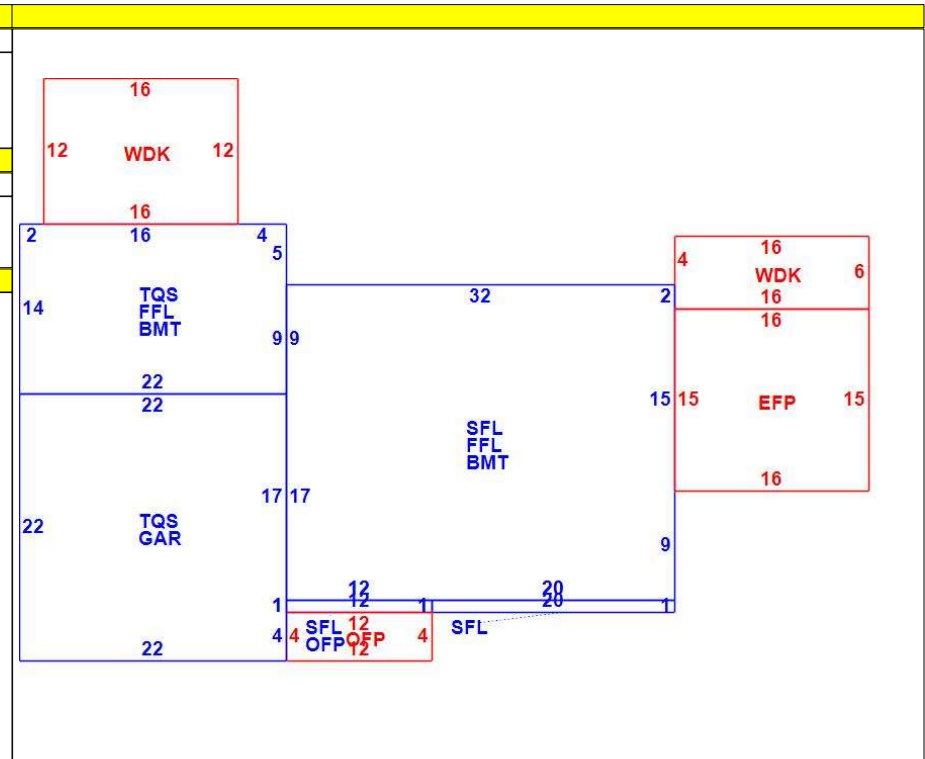

OB - OUTBUILDING & YARD ITEMS(L) / XF - BUILDING EXTRA FEATURES(B)													
Code	Description	Su	Sub Type	Lan	Units	Unit Price	Yr Blt	%	Dep.	Cond	Gra	Qual	Apprais Va
11	POOL I-V	OB	Outbuil	L	648	29.00	1985	70	0.00	GD	A	1.00	13,200
02	SHED/FR			L	96	12.00	1985	60	0.00	AV	A	1.00	700
14	SCRN HSE			L	64	20.00	1993	70	0.00	GD	G	1.25	1,100

BUILDING SUB-AREA SUMMARY SECTION							
Subarea	Description	Living	Gross	Eff Area	Unit Cost	Undeprec Value	
BMT	BASEMENT	0	1,140		28.44	32,417	
EFP	ENCL PORCH	0	240		71.09	17,061	
FFL	1ST FLOOR	1,140	1,140		142.18	162,083	
GAR	GARAGE	0	484		56.99	27,583	
OFF	OPEN PORCH	0	60		14.22	853	
SFL	2ND FLOOR	864	864		142.18	122,842	
TQS	3/4 STORY	594	792		106.63	84,454	
WDK	WOOD DECK	0	288		28.63	8,246	
Ttl Gross Liv / Lease Area		2,598	5,008			455,538	

