

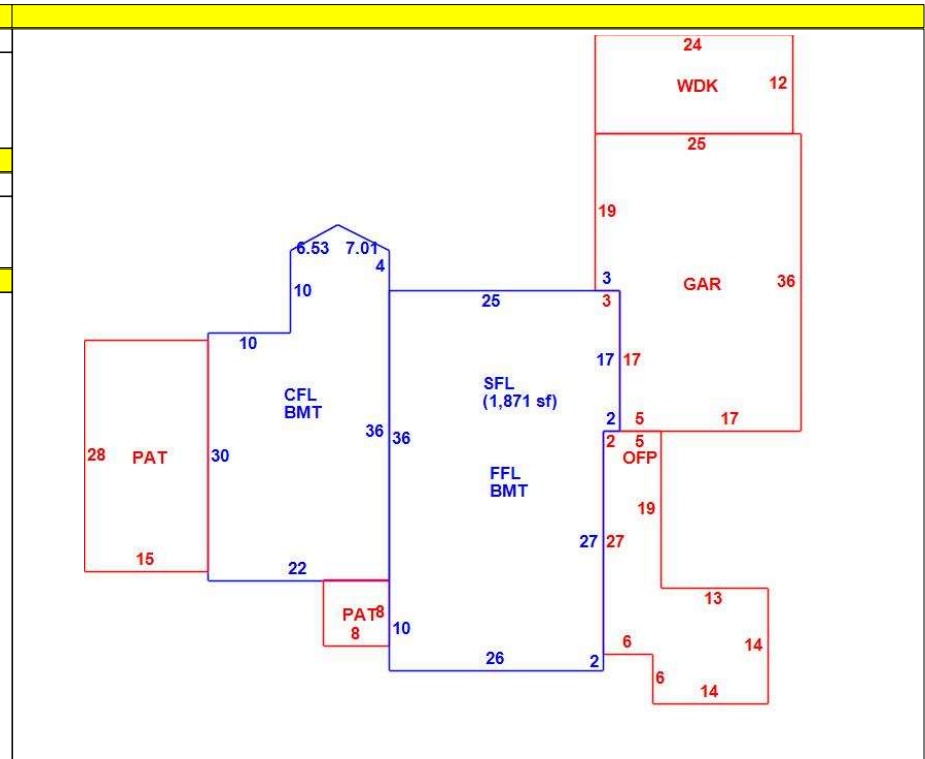

CONSTRUCTION DETAIL			CONSTRUCTION DETAIL (CONTINUED)		
Element	Cd	Description	Element	Cd	Description
Style	06	COLONIAL	Central Vac	1	YES
Model	01	RESIDENTIAL	Basement Floor	12	CONCRETE
Grade	B+	GOOD (+)	Bsmt Garage	0	
Stories	2.00	2 STORY	Units	1	
Foundation	1	CONCRETE	<b>MIXED USE</b>		
Exterior Wall 1	4	VINYL	Code	Description	
Exterior Wall 2	8	BRICK VENR	101	ONE FAM	100
Roof Structure	2	HIP			0
Roof Cover	1	ASPHALT SH			0
Interior Wall 1	1	DRYWALL	<b>COST / MARKET VALUATION</b>		
Interior Wall 2	4	CARPET	Adj Base Rate	99.07	
Interior Floor 1	3	HARDWOOD	RCN	661,808	
Interior Floor 2	2	GAS	Net Other Adj		
Heat Fuel	1	FORCED H/A	Year Built	2003	
Heat Type	03	FULL	Effective Year Built	2014	
AC Type	4		Depreciation Code	VG	
Bedrooms	3		Remodel Rating		
Full Baths	1		Year Remodeled		
Half Baths	0		Depreciation %	7	
Extra Fixtures	9		Functional Obsol		
Total Rooms	G	GOOD	External Obsol		
Bath Style	G	GOOD	Cost Trend Factor	1	
Half Bath Style	G	GOOD	Condition		
Kitchens	1		% Complete		
Kitchen Style	G	GOOD	Overall % Condition	93	
Extra Kitchens	0		RCNLD	615,500	
Extra Kitchen St	N	NONE	Dep % Ovr		
FBM Sqft			Dep Ovr Comment		
FBM Quality			Misc Imp Ovr		
FIN ATC Sqft			Misc Imp Ovr Comment		
FIN ATC Quality			Cost to Cure Ovr		
Fireplaces	1		Cost to Cure Ovr Comment		
WS Flues	0				



OB - OUTBUILDING & YARD ITEMS(L) / XF - BUILDING EXTRA FEATURES(B)													
Code	Description	Su	Sub Type	Lan	Units	Unit Price	Yr Blt	%	Dep.	Cond	Gra	Qual	Apprais Va
GEN	GENERATO			B	1	0.00	2013	93	1.00	AV	A	1.00	0
SOL	Solar Panels	EX	Extra Fea	B	1	0.00	2023	93	1.00	AV	A	0.00	0
02	SHED/FR			L	308	12.00	2023	60	0.00	AV	A	1.00	2,200

BUILDING SUB-AREA SUMMARY SECTION							
Subarea	Description	Living	Gross	Eff Area	Unit Cost	Undeprec Value	
BMT	BASEMENT	0	2,029		27.65	56,095	
CFL	CATHEDRAL CE	799	799		142.31	113,709	
FFL	1ST FLOOR	1,230	1,230		138.16	169,942	
GAR	GARAGE	0	849		55.33	46,976	
OPF	OPEN PORCH	0	377		13.93	5,250	
PAT	PATIO	0	484		6.85	3,316	
SFL	2ND FLOOR	1,871	1,871		138.16	258,506	
WDK	WOOD DECK	0	288		27.82	8,014	
Ttl Gross Liv / Lease Area		3,900	7,927			661,808	



**54 PINE GROVE CIR**